

PLEASE KEEP ME WITH YOUR PROOF OF PURCHASE FOR FUTURE REFERENCE



ASSEMBLY INSTRUCTIONS

Dubai/Sanza 3 Seat Lounge Sofa, Lounge Chair(x2) and 170 x50cm Casual Table

(69119012 / 69119023)

ATTENTION:









1. Please read these instructions carefully before assembly
2. Aluminium is soft metal and over tightening may strip thread or break the part
3. **DO NOT** use power tools
4. Please allow 30 minutes for assembly.
5. Although assembly only requires 1 person it is advised that a second person be present to help turn the table over and into position when fully assembled

LOUNGE CHAIR ASSEMBLY STEPS:

1. Turn the chair (A) upside down on a soft clean surface
2. **LOOSELY** attach Seating panel (B) to the chair (A) with 4 bolts (F), 2 bolts (G) and 6 big flat washers (H) using Allen key (I)
3. **LOOSELY** attach legs (C) to Sofa (A) with 6 bolts (G) and 6 big flat washers (H) using Allen key (I) **DO NOT TIGHTEN THE BOLTS AT THIS STAGE**
4. Tighten all bolts using Allen key (I) one by one being careful not to over tighten any as this will cause the thread to become damaged
5. Turn Sofa over and place in desired position.
6. Place all cushions (D&E) on the sofa seat

For more information regarding maintenance of your furniture please visit

http://www.hartmanuk.co.uk/after_care_videos.html

| Component's | | | | | Fixings | | | | |
|-------------|---|---------------|------|------------------------|------------|--|------------------|------|----------|
| Parts List | Parts Picture | Description | Q'ty | Part no | Parts list | Parts Picture | Description | Q'ty | Part no. |
| A |  | chair | 1 | 69119012A 69119023A | F |  | M6*35 bolts | 4 | 1111162 |
| | | | | | G |  | M6*25 bolts | 8 | 1231162 |
| B |  | Seating panel | 1 | 69119012B 69119023B | H |  | Big Flat washers | 12 | 1061162 |
| C |  | Leg | 2 | 69119012C 69119023C | I |  | Allen Key | 1 | 2002191 |
| D |  | Seat cushion | 1 | 69119012D 69119023D | | | | | |
| E |  | Back cushion | 1 | 69119012E 69119023E | | | | | |

For replacement or lost spare parts please go to <http://faq.hartmanuk.co.uk/spares/>

Should you have any queries about your furniture your first point of contact should be the retailer from whom you purchased your product

PLEASE KEEP ME WITH YOUR PROOF OF PURCHASE FOR FUTURE REFERENCE



ASSEMBLY INSTRUCTIONS

Lounge Chair(x2)

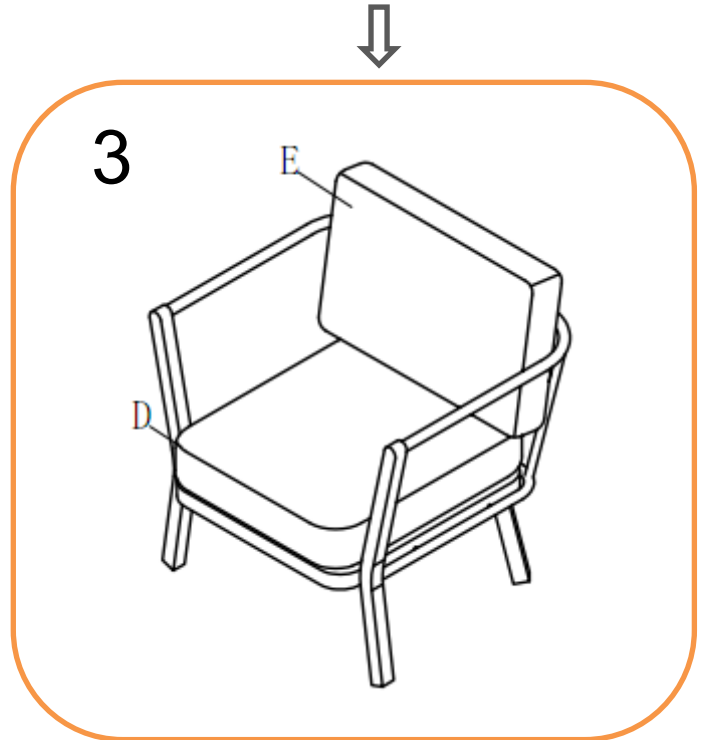
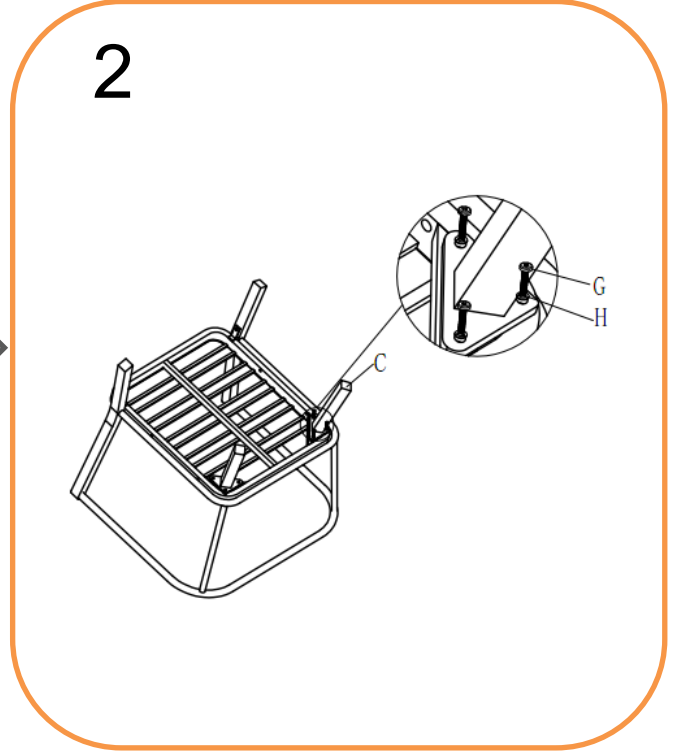
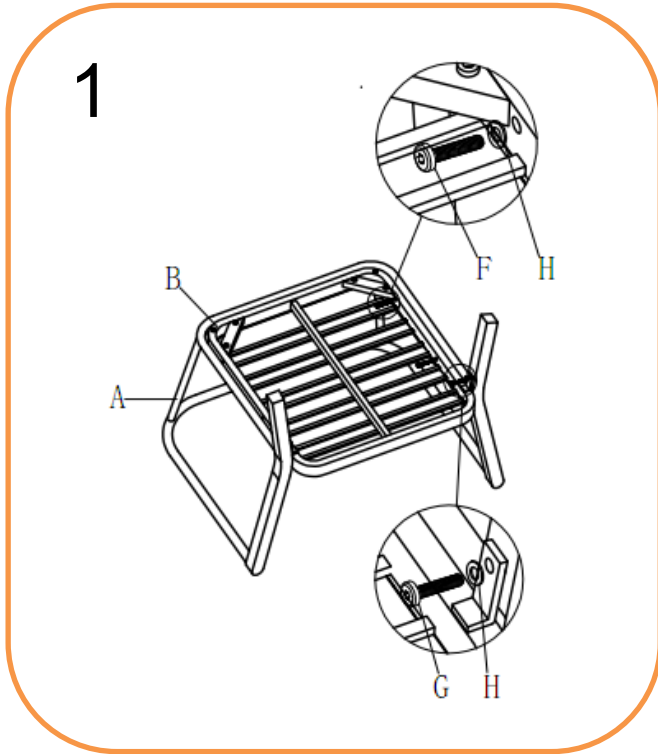

For replacement or lost spare parts please go to <http://faq.hartmanuk.co.uk/spares/>
Should you have any queries about your furniture your first point of contact should be the retailer from whom you purchased your product

PLEASE KEEP ME WITH YOUR PROOF OF PURCHASE FOR FUTURE REFERENCE

ATTENTION:











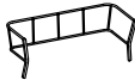

1. Please read these instructions carefully before assembly
2. Aluminium is soft metal and over tightening may strip thread or break the part
3. **DO NOT** use power tools
4. Please allow 30 minutes for assembly.
5. Although assembly only requires 1 person it is advised that a second person be present to help turn the table over and into position when fully assembled

3 SEAT SOFA ASSEMBLY STEPS:

1. Turn the sofa (A) upside down on a soft clean surface
2. **LOOSELY** attach Seating panel (B) to the Sofa (A) with bolts (H), bolts (I) and big flat washers (K) using Allen key (L)
3. **LOOSELY** attach 2 legs (C) to Sofa (A) with bolts (I) and big flat washers (K) using Allen key (L) **DO NOT TIGHTEN THE BOLTS AT THIS STAGE**
4. **LOOSELY** attach middle leg (D) to seating panel (B) with bolts (I) and big flat washers (K) using Allen key (L)
5. **LOOSELY** attach rear middle leg (E) to seating panel (B) with bolts (J) and big flat washers (K) using Allen key (L)
6. Tighten all bolts using Allen key (L) one by one being careful not to over tighten any as this will cause the thread to become damaged
7. Turn Sofa over and place in desired position.
8. Place all cushions(F&G) on the sofa seat

For more information regarding maintenance of your furniture please visit

http://www.hartmanuk.co.uk/after_care_videos.html

| Component's | | | | | Fixings | | | | |
|-------------|---|-----------------|------|--------------------------|------------|--|------------------|------|----------|
| Parts List | Parts Picture | Description | Q'ty | Part no | Parts list | Parts Picture | Description | Q'ty | Part no. |
| A |  | Sofa | 1 | 69119012A1 69119023A1 | F |  | Seat cushion | 1 | |
| | | | | | G |  | Back cushion | 3 | |
| B |  | Seating panel | 1 | 69119012B1 69119023B1 | H |  | M6*35 bolts | 8 | |
| C |  | Rear Leg | 2 | 69119012C1 69119023C1 | I |  | M6*25 bolts | 12 | |
| D |  | Middle leg | 1 | 69119012D1 69119023D1 | J |  | M6*15 bolts | 2 | |
| E |  | Rear middle leg | 1 | 69119012E1 69119023E1 | K |  | Big Flat washers | 22 | |
| | | | | | L |  | Allen Key | 1 | |

For replacement or lost spare parts please go to <http://faq.hartmanuk.co.uk/spares/>

Should you have any queries about your furniture your first point of contact should be the retailer from whom you purchased your product

PLEASE KEEP ME WITH YOUR PROOF OF PURCHASE FOR FUTURE REFERENCE

ASSEMBLY INSTRUCTIONS

Dubai/Sanza 3 Seat Sofa

1

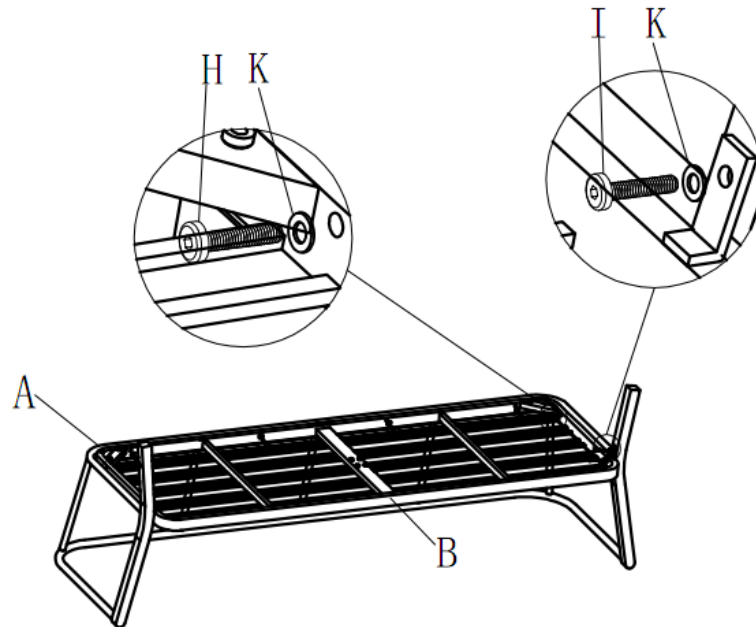

2

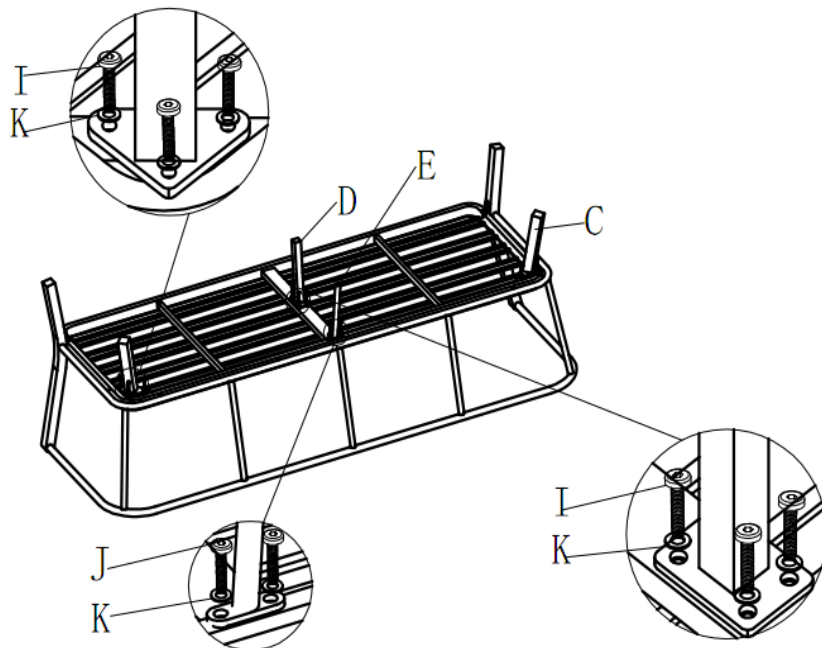

For replacement or lost spare parts please go to <http://faq.artmanuk.co.uk/spares/>
Should you have any queries about your furniture your first point of contact should be the retailer from whom you purchased your product

PLEASE KEEP ME WITH YOUR PROOF OF PURCHASE FOR FUTURE REFERENCE

3

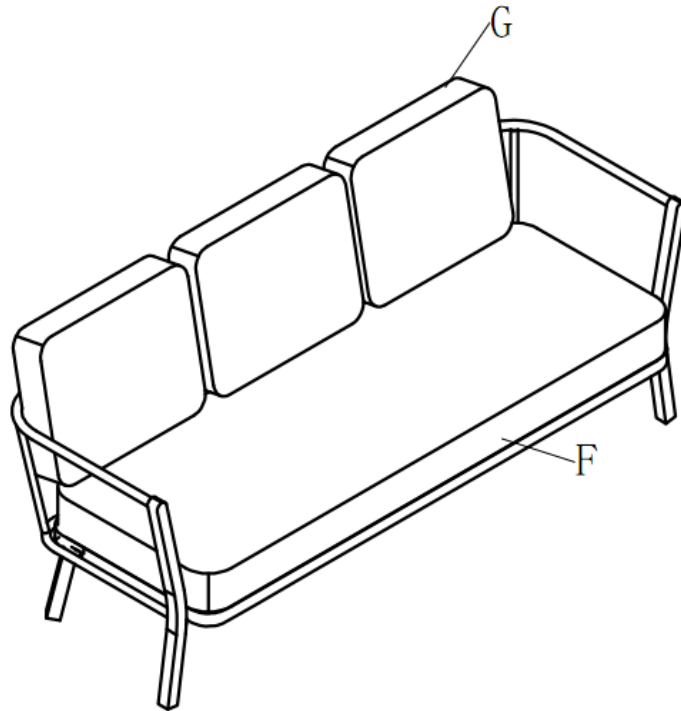

For replacement or lost spare parts please go to <http://faq.hartmanuk.co.uk/spares/>
Should you have any queries about your furniture your first point of contact should be the retailer from whom you purchased your product

PLEASE KEEP ME WITH YOUR PROOF OF PURCHASE FOR FUTURE REFERENCE

ATTENTION:







1. Please read these instructions carefully before assembly
2. Aluminium is soft metal and over tightening may strip thread or break the part
6. **DO NOT** use power tools
3. Please allow 30 minutes for assembly.
4. Although assembly only requires 1 person it is advised that a second person be present to help turn the table over and into position when fully assembled.

170 x 50cm Casual Table ASSEMBLY STEPS:

1. Turn the table top (A) upside down on a soft clean surface
2. **LOOSELY** attach leg (B) to table top (A) with bolts (E) and big flat washers (F) using Allen key (G) **DO NOT TIGHTEN THE BOLTS AT THIS STAGE**
3. **LOOSELY** attach the ring (C) to legs (B) with bolts (E) and big flat washers (F) using Allen key (G) **DO NOT TIGHTEN THE BOLTS AT THIS STAGE**
4. Tighten all bolts using Allen key (G) one by one being careful not to over tighten any as this will cause the thread to become damaged
5. Turn over and place in desired position.
6. Place glass (D) back on table and gently press down on suckers to ensure glass is secure

For more information regarding maintenance of your furniture please visit

http://www.hartmanuk.co.uk/after_care_videos.html

| Component's | | | | | Fixings | | | | |
|-------------|---|-------------|------|--------------------------|------------|---|------------------|------|----------|
| Parts List | Parts Picture | Description | Q'ty | Part no | Parts list | Parts Picture | Description | Q'ty | Part no. |
| A |  | Table top | 1 | 69119012A2 69119023A2 | E |  | M6*25 bolts | 12 | |
| | | | | | F |  | Big Flat washers | 12 | |
| B |  | Leg | 4 | 69119012B2 69119023B2 | G |  | Allen Key | 1 | |
| C |  | Ring | 1 | 69119012C2 69119023C2 | | | | | |
| D |  | Glass | 1 | 69119012D2 69119023D2 | | | | | |

For replacement or lost spare parts please go to <http://faq.hartmanuk.co.uk/spares/>

Should you have any queries about your furniture your first point of contact should be the retailer from whom you purchased your product

PLEASE KEEP ME WITH YOUR PROOF OF PURCHASE FOR FUTURE REFERENCE
ASSEMBLY INSTRUCTIONS

170 x50cm Casual Table

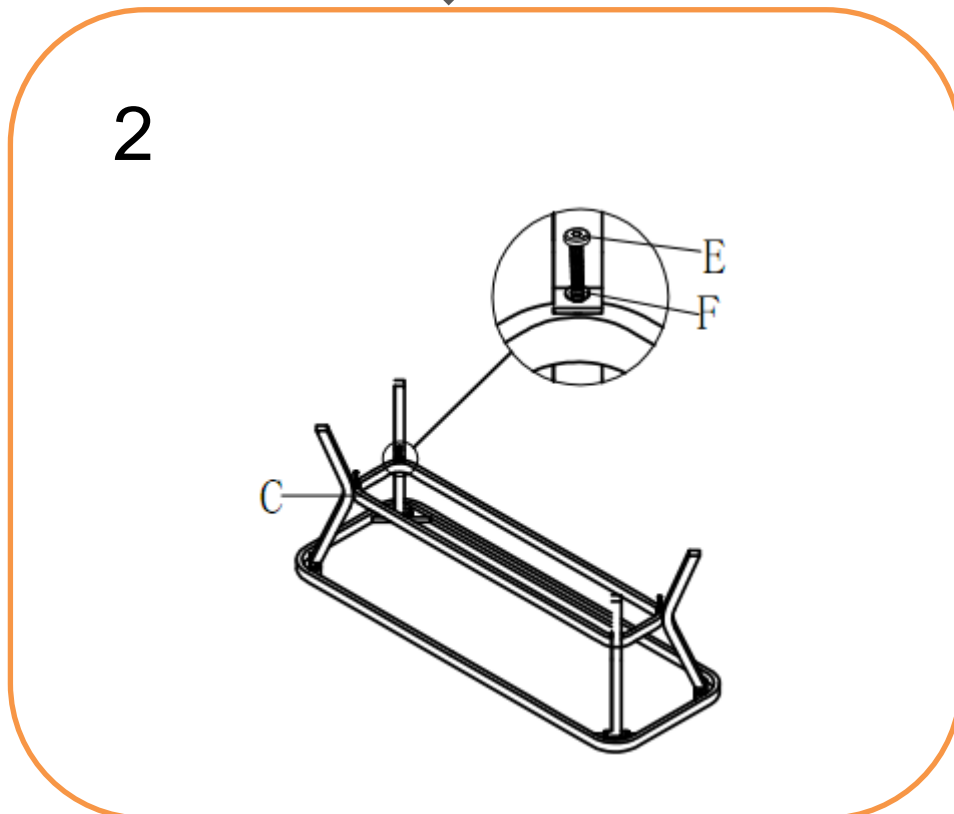
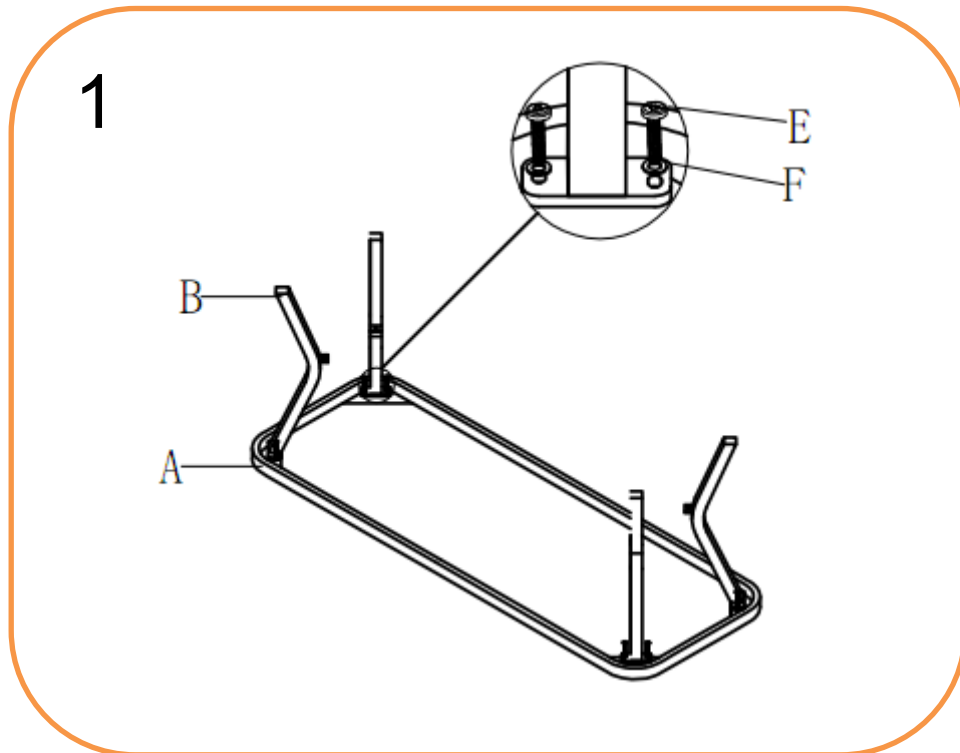

For replacement or lost spare parts please go to <http://faq.hartmanuk.co.uk/spares/>
Should you have any queries about your furniture your first point of contact should be the retailer from whom you purchased your product

PLEASE KEEP ME WITH YOUR PROOF OF PURCHASE FOR FUTURE REFERENCE



3

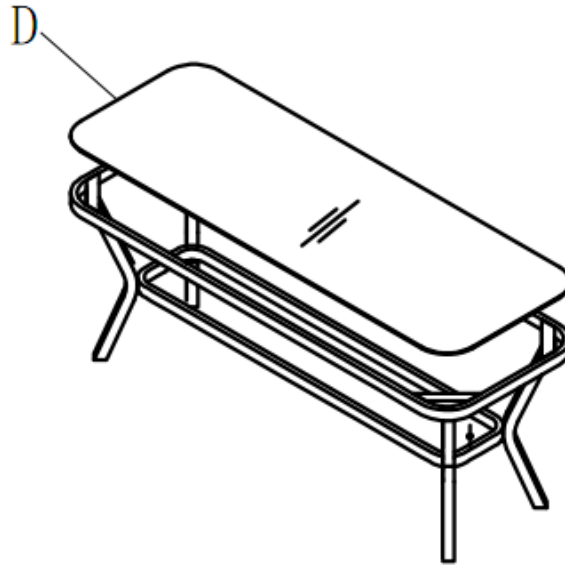

4

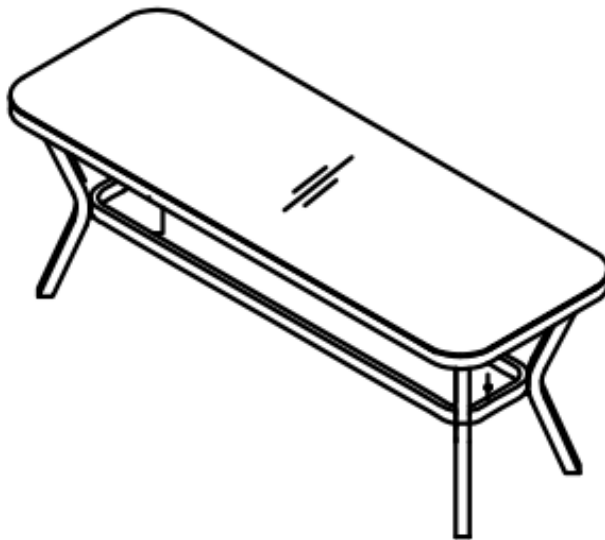

For replacement or lost spare parts please go to <http://faq.hartmanuk.co.uk/spares/>
Should you have any queries about your furniture your first point of contact should be the retailer from whom you purchased your product